

ATKOMATIC

7000 Series

Stainless Steel, Pilot-piston, Pressure 5 to 6000 psig (0.4 to 414 bar)
High Pressure Valve Configurable for Variety of Fluid Applications



Features

- Pressure to 6000 psig (414 bar)
- Pilot operated: require a minimum pressure differential of 5 psig (0.4 bar)
- Barstock body configuration
- Fluid temperatures of -423°F (-253°C) through $+500^{\circ}\text{F}$ ($+260^{\circ}\text{C}$) (Kel-F[®] piston recommended for -400°F (-240°C) through $+400^{\circ}\text{F}$ ($+204^{\circ}\text{C}$))
- All 316 stainless steel construction on pressure containing parts; plunger material is 416 stainless that is treated for increased corrosion resistance
- Will handle fluids with viscosity up to 200 SUS
- Suitable for use with wide variety of fluid including: air, gasses, liquids, hydraulic fluids, steam, cryogenic fluids, and corrosive fluids
- Piston material (same as seat material) of PCTFE or 17-4 stainless steel
- Body seal materials of PTFE, Viton[®], Buna N, or EPR
- Pipe ports of $\frac{1}{4}$ ", $\frac{3}{8}$ ", or $\frac{1}{2}$ " NPT (British BSPT ports available)
- Flow orifice of $\frac{5}{16}$ "
- Cv from 1.0 to 2.0
- Uses a class H fiberglass wrapped, double wound coil (requires use with a relay to drop put primary coil winding after valve actuation)
- Coil housings available in NEMA 1 (standard), NEMA 4 (waterproof), NEMA 7 (explosion-proof for hazardous locations), and combination NEMA 4 & 7

Operational Pressures (5 psi minimum pressure differential)

GASES		LIQUIDS TO 40 SUS		LIQUIDS OVER 40 SUS		STEAM	
AC	DC	AC	DC	AC	DC	AC	DC
6000	4000	6000	3500	6000	2500	300	300
414 bar	276 bar	414 bar	242 bar	414 bar	173 bar	21 bar	21 bar

Circle Seal Controls

2301 Wardlow Circle • P.O. Box 3300 • Corona, CA 92880

Phone (951) 270-6200 Fax (951) 270-6201

www.circlesealcontrols.com • am_sales@circlesealcontrols.com • ind_sales@circlesealcontrols.com

atkomatic solenoid

7000 Series

Dimensions, Shipping Weights, and Cv Flow Factors

CATALOG NUM. PREFIX	PIPE SIZE	MAIN SEAT ORIFICE	X	Y	Z	SHIPPING WEIGHT (lbs)	Cv
7004	1/4"	5/16"	7 7/16"	6"	2 3/4"	7	1.0
7104	3/8"	5/16"	7 7/16"	6"	2 3/4"	7	2.0
7204	1/2"	5/16"	7 7/16"	6"	2 3/4"	7	2.0

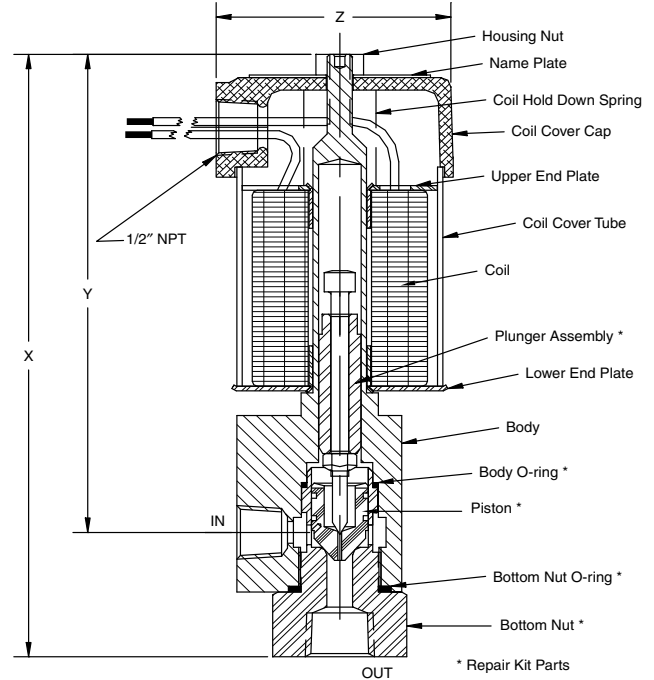

7104 3/8" Valve, shown with a NEMA 1 coil housing

How to Order

7 x 0 4 - x x x x x x x x x x

CONNECTION SIZES

0 1/4"
1 3/8"
2 1/2"

VOLTAGE AC/60 Hz

0 AC/60 Hz or DC voltage
1 100 VAC 3 200 VAC 5 460 VAC
2 115 VAC 4 230 VAC 6 550 VAC

VOLTAGE AC/50 Hz

0 AC/60 Hz or DC voltage
1 110 VAC 2 220 VAC

VOLTAGE DC

0 AC voltage
1 24 & 32 VDC 3 125 VDC
2 48 VDC 4 250 VDC

CONNECTION TYPE

P NPT
J British pipe thread

COIL HOUSING

E Explosion-proof
S Standard
W Waterproof
C Combined water- & explosion-proof

FLUID MEDIA TYPE

1 Gas
2 Liquid up to 40 SUS
3 Liquid from 41 SUS to 150 SUS
4 Steam
5 Cryogenic

SEAL MATERIAL

A PTFE B Buna N
C Viton® D EPR

SEAT/PISTON MATERIAL

1 PCTFE
2 Stainless steel
3 Stainless steel piston with Stellite® stem

MAX. OPERATING PRESS (psig)

A 300	E 1000	I 3500
B 500	F 1500	J 4000
C 700	G 2000	K 5000
D 800	H 2500	L 6000

Viton® is a registered trademark of DuPont Dow Elastomers.
Stellite® is a registered trademark of Deloro Stellite Company Inc.